

PLATFORM SCALES

5g to 1ton

Features :

- ♦ Low Profile construction with S.S. ramp (Optional) to avoid pit in production area.
- ♦ Incorporates multiple number (4 nos) of high quality stainless steel IP 67/68 shear beam loadcells.
- ♦ Stainless Steel S.S. 202 Platform (S.S.304/ S.S.316 optional).
- ♦ Stainless Steel IP67 GLP compliant Indicator with Real Time Clock (Optional).
- ♦ Large LCD display with white backlite.

Specifications :

Models	CP-3001
Capacity	3000g
Readability	0.1g
Linearity (+/-)	0.1g
Platform Size(mm)	400x400

Taring Range : Up to full capacity

Response time : 3-5 secs

Power Req : 90-250V, 50/60Hz, 10 Watt

Operating Temperature : 10 to 45 deg C

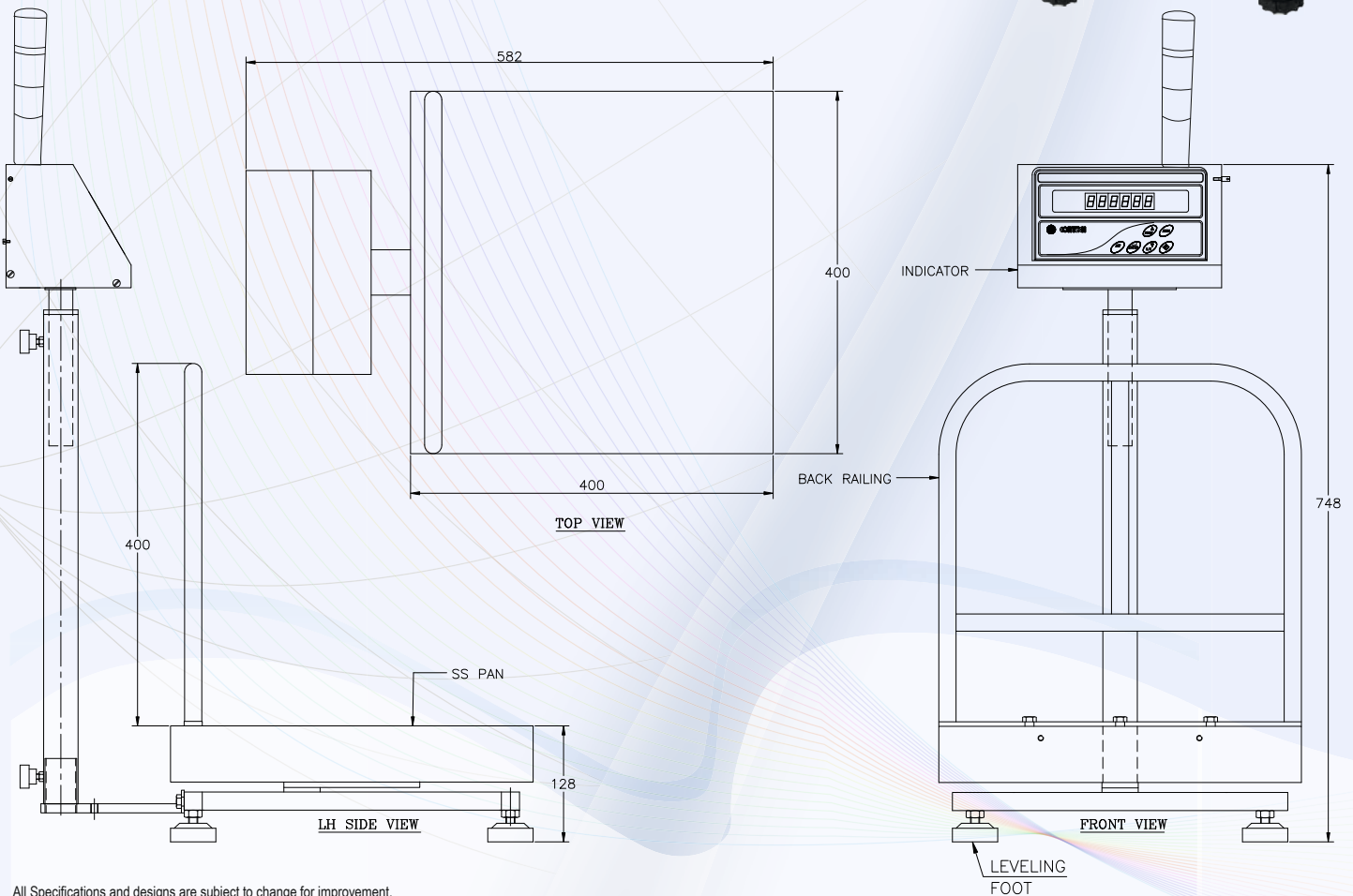

All Specifications and designs are subject to change for improvement.

PLATFORM SCALES

5g to 1ton

Features :

- ◆ Indicator housed in a sturdy metal enclosure.
- ◆ Bright LED display.
- ◆ Multiple functions: Parts counting, accumulation, net/gross.
- ◆ Standard bi-directional RS-232 interface.
- ◆ Overload & shock load protection.
- ◆ Bright Red LED display.
- ◆ High bright green LED display (optional).
- ◆ Battery backup (optional).
- ◆ Rechargeable sealed maintenance free battery.

Specifications :

Models	CP-1T100
Capacity	1ton
Readability	100g
Platform Sizes(mm)	750x750

Taring Range : Up to full capacity
 Response time : 3-5 secs
 Power Req : 90-250V, 50/60Hz, 10 Watt
 Operating Temperature : 10 to 45 deg C

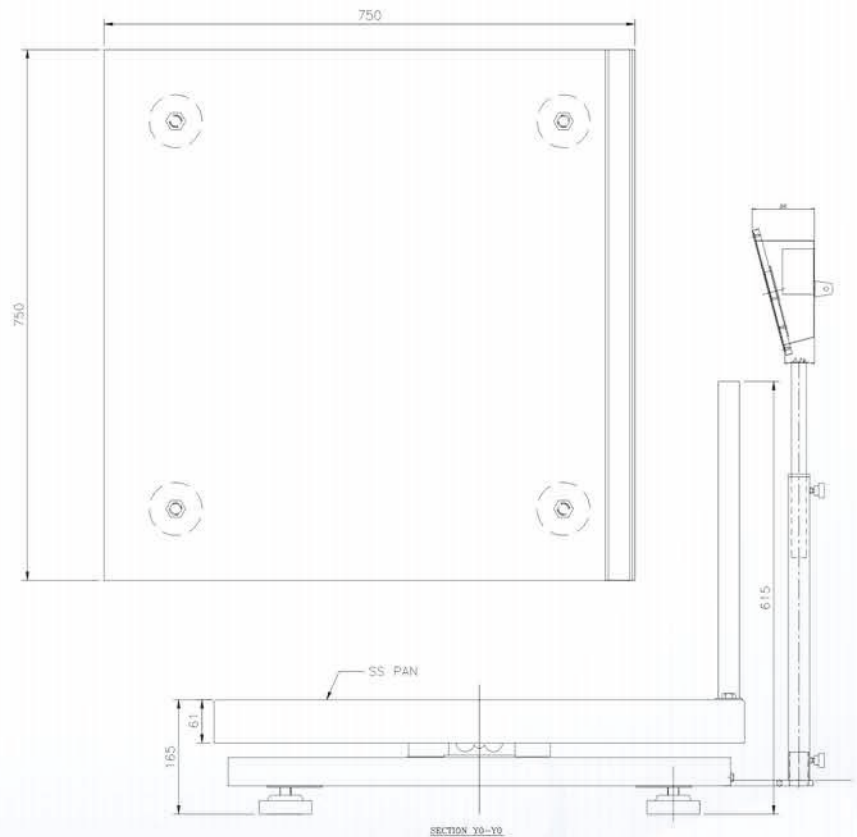
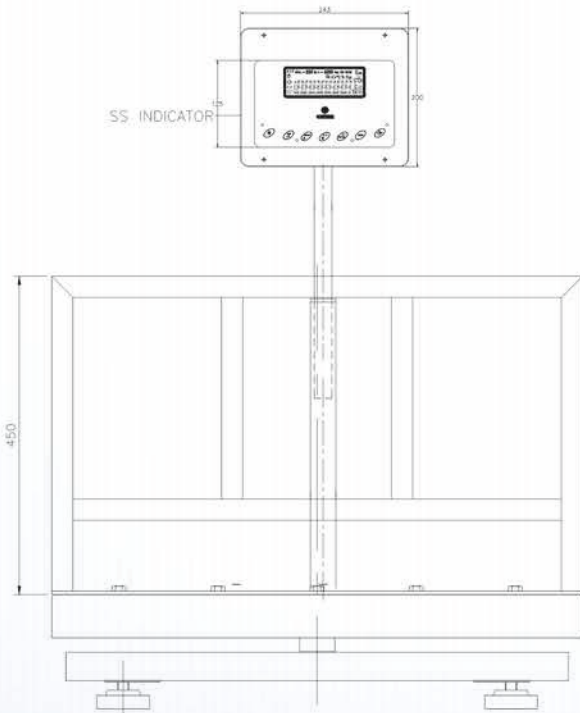

All Specifications and designs are subject to change for improvement.

PLATFORM SCALES

5g to 1ton

Features :

- ◆ Indicator housed in a sturdy metal enclosure.
- ◆ Bright LED display.
- ◆ Multiple functions: Parts counting, accumulation, net/gross.
- ◆ Standard bi-directional RS-232 interface.
- ◆ Overload & shock load protection.
- ◆ Bright Red LED display.
- ◆ High bright green LED display (optional).
- ◆ Battery backup (optional).
- ◆ Rechargeable sealed maintenance free battery.

Specifications :

Models	CP-200K20
Capacity	200kg
Readability	20g
Platform Sizes(mm)	600x600



Taring Range : Up to full capacity
 Response time : 3-5 secs
 Power Req : 90-250V, 50/60Hz, 10 Watt
 Operating Temperature : 10 to 45 deg C

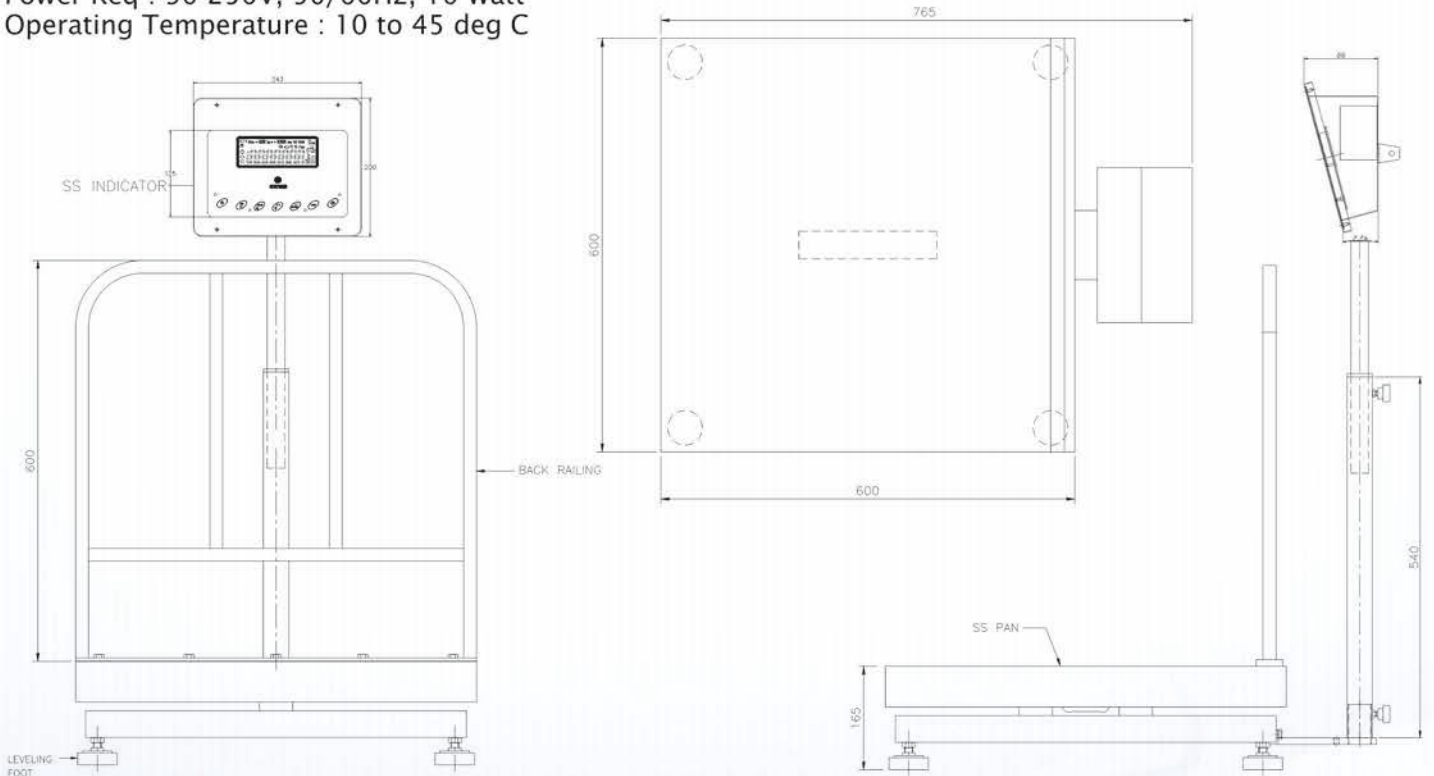

All Specifications and designs are subject to change for improvement.

PLATFORM SCALES

5g to 1ton

Features :

- ◆ Indicator housed in a sturdy metal enclosure.
- ◆ Bright LED display.
- ◆ Multiple functions: Parts counting, accumulation, net/gross.
- ◆ Standard bi-directional RS-232 interface.
- ◆ Overload & shock load protection.
- ◆ Bright Red LED display.
- ◆ High bright green LED display (optional).
- ◆ Battery backup (optional).
- ◆ Rechargeable sealed maintenance free battery.

Specifications :

Models	CP-500K100
Capacity	500kg
Readability	100g
Platform Sizes(mm)	750x750

Taring Range : Up to full capacity
 Response time : 3-5 secs
 Power Req : 90-250V, 50/60Hz, 10 Watt
 Operating Temperature : 10 to 45 deg C

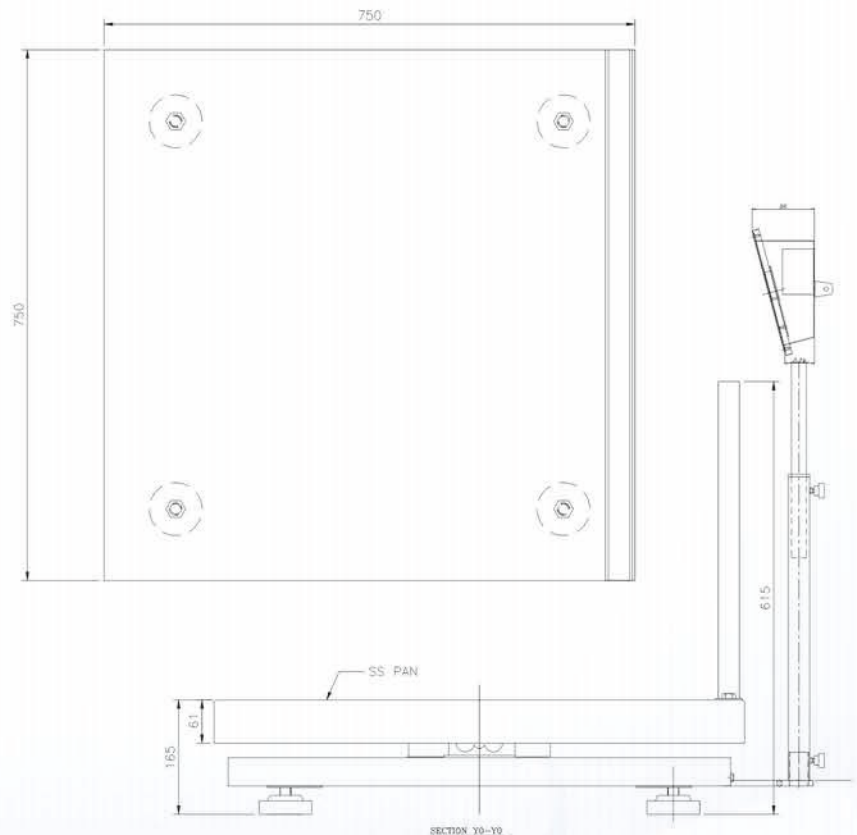
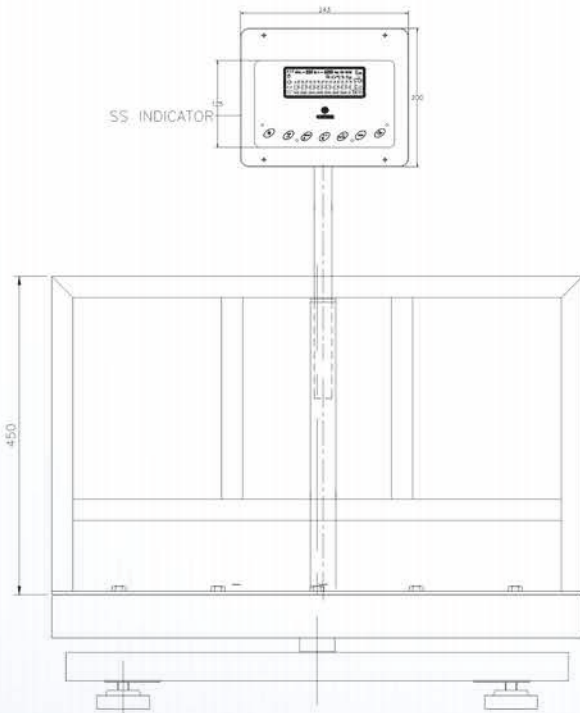

All Specifications and designs are subject to change for improvement.

PLATFORM SCALES

5g to 1ton

Features :

- ◆ Indicator housed in a sturdy metal enclosure.
- ◆ Bright LED display.
- ◆ Multiple functions: Parts counting, accumulation, net/gross.
- ◆ Standard bi-directional RS-232 interface.
- ◆ Overload & shock load protection.
- ◆ Bright Red LED display.
- ◆ High bright green LED display (optional).
- ◆ Battery backup (optional).
- ◆ Rechargeable sealed maintenance free battery.

Specifications :

Models	CP-50K5
Capacity	50kg
Readability	5g
Platform Sizes(mm)	400x400

Taring Range : Up to full capacity
 Response time : 3-5 secs
 Power Req : 90-250V, 50/60Hz, 10 Watt
 Operating Temperature : 10 to 45 deg C

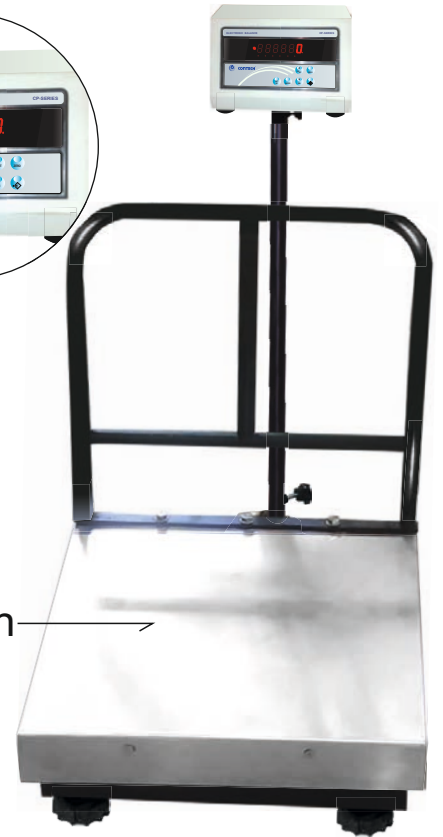

S S 304 Pan

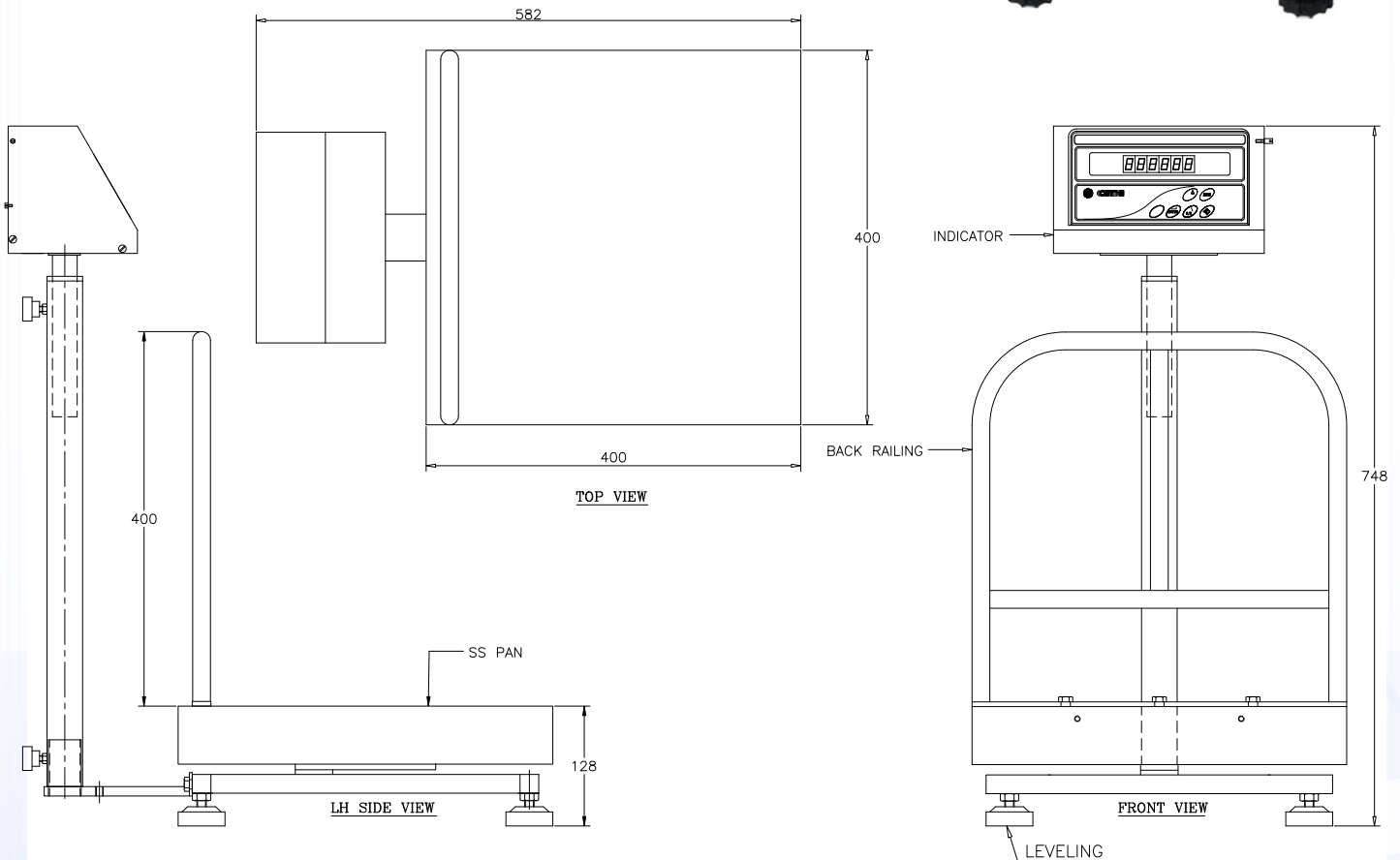

All Specifications and designs are subject to change for improvement.

PLATFORM SCALES

5g to 1ton

ABS Indicator



S S Backrailing

S S 304 Pan

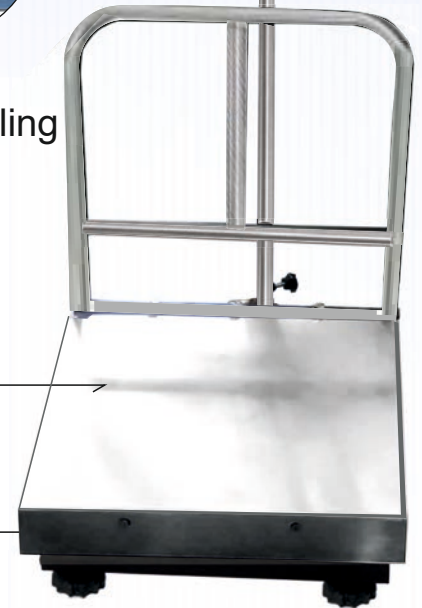

Features :

- ◆ Indicator housed in a sturdy metal enclosure.
- ◆ Bright LED display.
- ◆ Multiple functions: Parts counting, accumulation, net/gross.
- ◆ Standard bi-directional RS-232 interface.
- ◆ Overload & shock load protection.
- ◆ Bright Red LED display.
- ◆ High bright green LED display (optional).
- ◆ Battery backup (optional).
- ◆ Rechargeable sealed maintenance free battery.

Specifications :

Models	CP-100K10
Capacity	100kg
Readability	10g
Platform Sizes(mm)	600x600

Taring Range : Up to full capacity
 Response time : 3-5 secs
 Power Req : 90-250V, 50/60Hz, 10 Watt
 Operating Temperature : 10 to 45 deg C

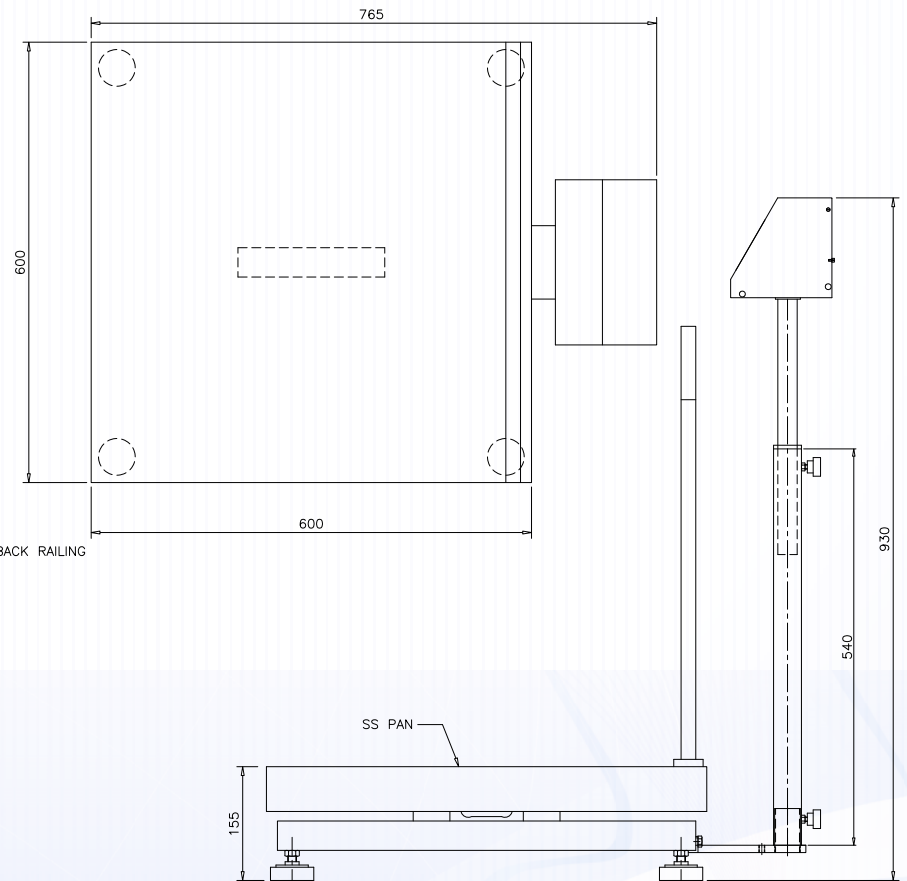
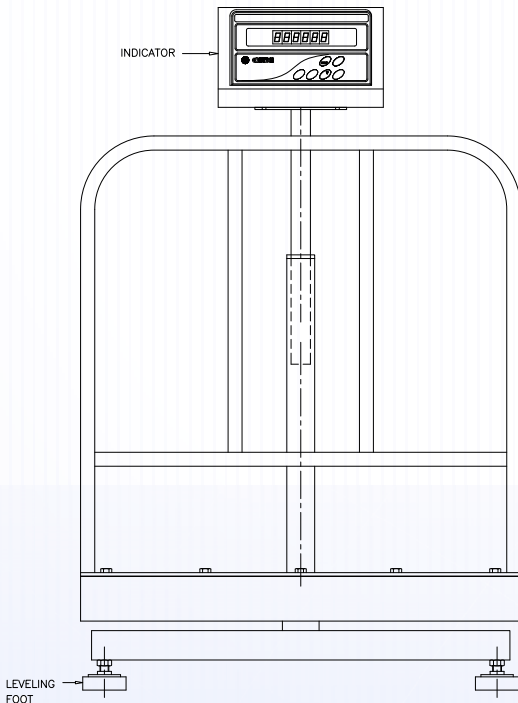

All Specifications and designs are subject to change for improvement.



CONTECH
Instruments Ltd.

Where innovation never stops.....

301, Punit Indl. Premises, Turbhe Naka, Navi Mumbai - 400 705.
 Tel. : +91 22 6139 3000 (100 lines)
 E-mail : sales@contechindia.in
 Website: www.contechindia.com

FACTORY



Plot No. EL-221 TTC Indl. Area, MIDC (Electronic Zone),
 Mhape, Navi Mumbai - 400 710.

PLATFORM SCALES

5g to 1ton

Features :

- ◆ Indicator housed in a sturdy metal enclosure.
- ◆ Bright LED display.
- ◆ Multiple functions: Parts counting, accumulation, net/gross.
- ◆ Standard bi-directional RS-232 interface.
- ◆ Overload & shock load protection.
- ◆ Bright Red LED display.
- ◆ High bright green LED display (optional).
- ◆ Battery backup (optional).
- ◆ Rechargeable sealed maintenance free battery.

Specifications :

Models	CP-200K20
Capacity	200kg
Readability	20g
Platform Sizes(mm)	750x750

Taring Range : Up to full capacity
 Response time : 3-5 secs
 Power Req : 90-250V, 50/60Hz, 10 Watt
 Operating Temperature : 10 to 45 deg C

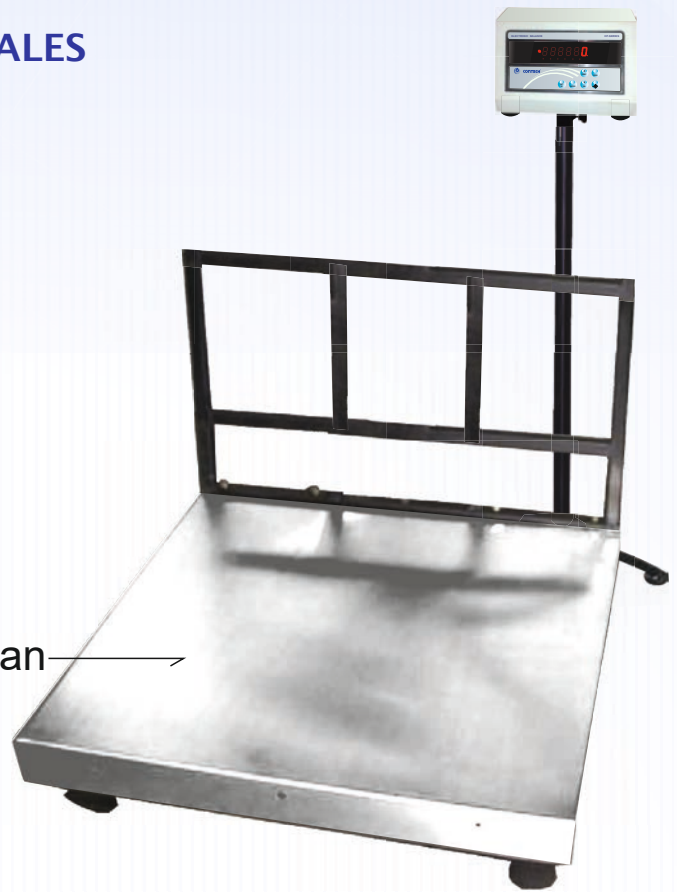

S S 304 Pan →

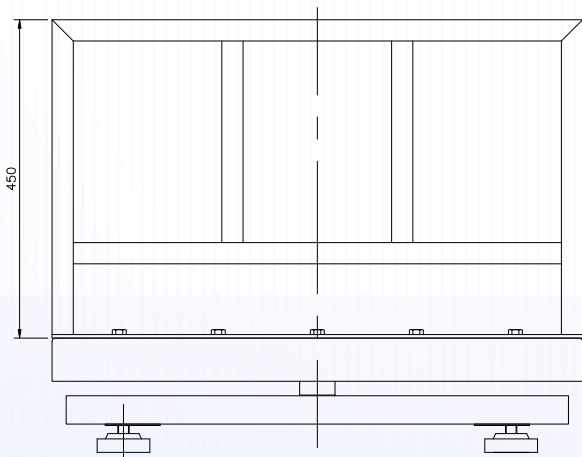
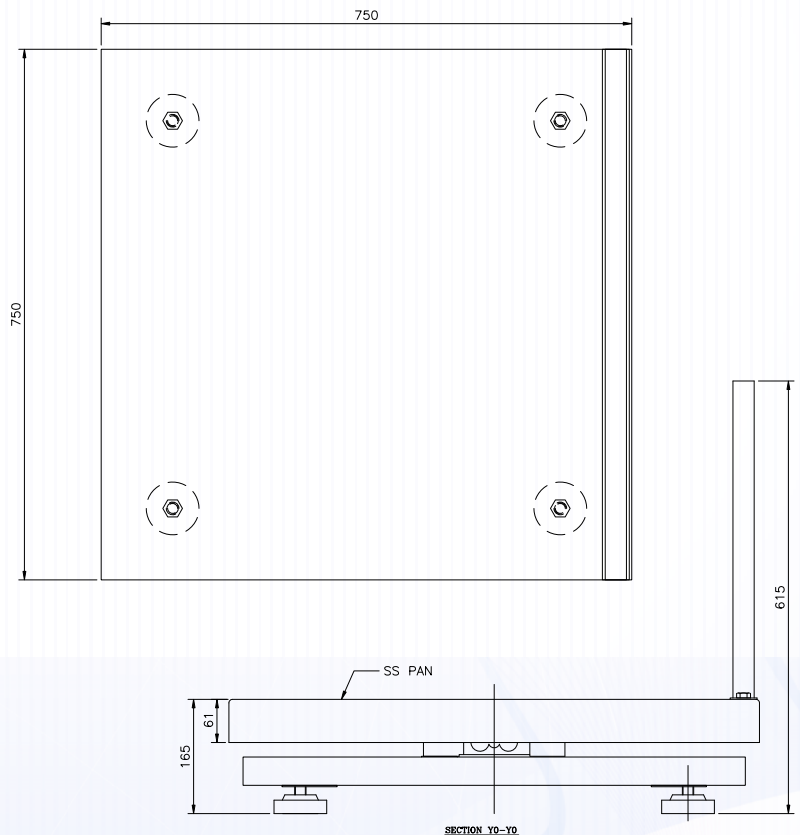

All Specifications and designs are subject to change for improvement.



CONTECH[®]
Instruments Ltd.
 Where innovation never stops.....

301, Punit Indl. Premises, Turbhe Naka, Navi Mumbai - 400 705.
 Tel. : +91 22 6139 3000 (100 lines)
 E-mail : sales@contechindia.in
 Website: www.contechindia.com



Plot No. EL-221 TTC Indl. Area, MIDC (Electronic Zone),
 Mhape, Navi Mumbai - 400 710.